

DESIGN OF A PUBLIC DC GRID OF A BUSINESS PARK

W.A.G. de Jager, P.J. Bos
DYNNIQ
Bijldorp-West 19
Barendrecht, the Netherlands
Tel.: +31 33 454 17 77
E-Mail: will.dejager@dynniq.com, peter.bos@dynniq.com
URL: <http://dynniq.com/>

Keywords

Active Front-End, DC power supply, Distribution of electrical energy, IGBT, System integration.

Abstract

This paper describes the design of a DC grid as a utility grid of a business park. The center of the DC grid is a DC substation. The DC substation is supplied from the MV AC grid. With a transformer and an Active Front-End, the AC voltage of 10 kV is transformed into 750 VDC. At customer side, the 750 VDC is converted to the required DC voltage for his application.

Introduction

Alternating Current (AC) is historically the standard for application in electrical grids. At the time of electrification Direct Current (DC) was technical insufficient usable.

However, this has changed by various technical and social developments here in recent decades. Decentralized energy generators like solar panels produce direct current. All products with a battery, such as laptops, mobile phones and electric cars, are working on direct current. It is estimated that 80 to 85 percent of all electrical devices are working on DC.

The conversion from AC to DC (or in the case of feed-in of renewable energy vice versa) yields energy loss. A DC utility grid that connects the DC users directly to each other can save energy by reducing the number of conversions and the need of fewer materials.

Several studies, like [1] show that distribution on DC not only improves the compatibility between DC consumer and generator, but that it is also technical and economical profitable [2].

Also studies have proved that more power can be transported by DC than AC through the same cable. This is because the DC voltage can have the same value as the peak value of the AC voltage. This results in a $\sqrt{2}$ higher transported power. Further, all transported DC power is real power, in contrast to AC, where, dependent of the power factor, also reactive power is transported. Therefore, more than 1.5 times DC power than AC can be transported over the same cable.

The pilot

On a new to build business park OMALA near Lelystad Airport, the Distribution System Operator (DSO) intends to realize a DC grid. Companies that want to settle on the nearby business park are potential customers. Several public functions will be realized on site, such as roads, energy, public lighting and charging stations for electric cars. The companies that settle in the area, can use besides a normal AC connection, also a DC connection. Applying a DC grid in this form is unique in this innovative project.

Goals

The goals of the DC grid are the following:

- A well-functioning public DC grid.
- A functional DC grid with eye for customer satisfaction.
- Safety.
- Reliability and availability.
- Easily expandable and affordable.

Requirements

Figure 1 shows the DC network as an example with three different types of customer connections. Up to 8 client connections will be realized to the DC distribution board. The DC grid must be designed such that customers up to 750 meters of cable length (effective length) can be connected to the DC substation.

The power of the DC power supply point itself has a maximum of 1,000 kW. Which types of customer and the amount of power are to be connected, is depending on the customer's request, but fall into the scale below.

- DC connections up to 50 kW.
- DC connections up to 100 kW.
- DC connections up to 200 kW.
- DC connections up to 500 kW.

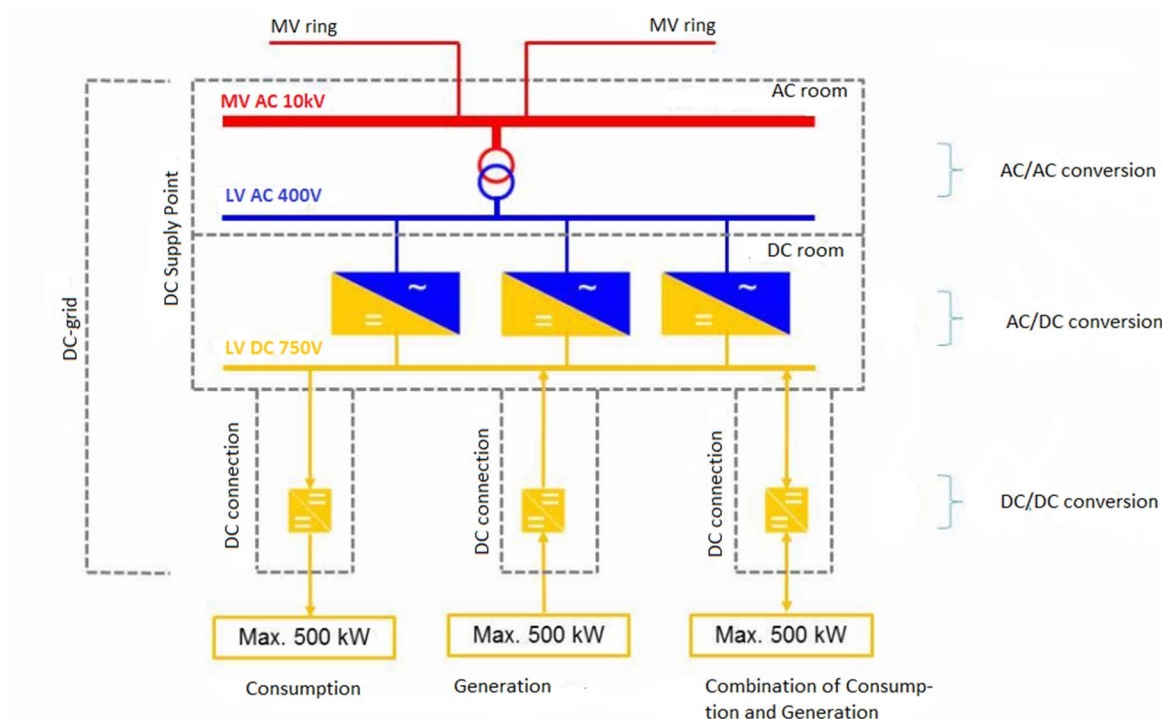

Figure 1: Principle diagram DC grid

Three types of customers can be distinguished:

- Customers who have only equipment that consumes energy, like a charging point for electrical vehicles or heat pump.
- Customers who have only equipment that generates energy, like solar panels.
- Customers that have installations that consume and supply, like a building with heat pumps and solar panels on the roof.

Boundary Conditions

- The design must be applicable for all DC applications such as solar panels, charging points, lighting, etc.
- The DC grid needs to be safe for humans, animals and the environment. It should be safe at all times to work on the DC network. The customer should be able to use his DC applications at all times.
- The reliability and availability of a DC connection must be ensured.
- Conducting work and extensions to the DC grid should be possible without leading to outages for customers.
- The protection of the DC grid should be designed such that errors are switched off selectively.
- An error in the DC grid may not cause faults or hazardous situations in the AC grid.
- Safe grounding in both the DC distribution station and the consumer.
- Energy exchange between AC and DC may have two directions (generate and consume).
- Standard available DC and AC components should be used as much as possible.
- A fall back scenario, to convert the DC network into a standard AC mains should be foreseen. When constructing to the DC grid should therefore be used as much as possible from AC standard components.
- Capacity of the AC compact room less than 1 MVA.
- The operating voltage of the DC network should be lower than 1,500 V, according to the European Union directive 2006/95/EC [3].
- DC network must be designed such that customers to 750 meters cable length (actual length) can be connected to the DC substation with max. 5% voltage drop.
- The impact of the DC grid on the rear AC grid should meet the power quality to requirements in accordance with EN 50160.

System Design

Two different structures can be chosen for the LVDC distribution system: a unipolar or bipolar layout [4], as shown in figure 2 and 3. They differ in the layout and the number of poles. Further difference is that a bipolar system requires a transformer with two secondary windings, while for a unipolar system a transformer with a single secondary winding is sufficient.

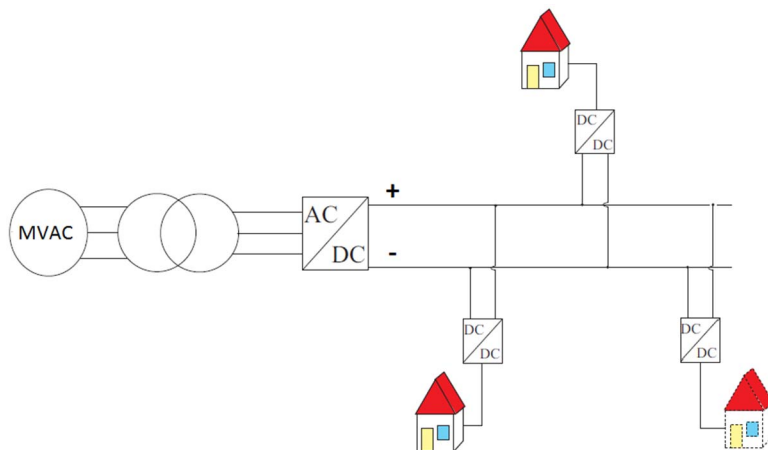

Figure 2: Unipolar DC grid

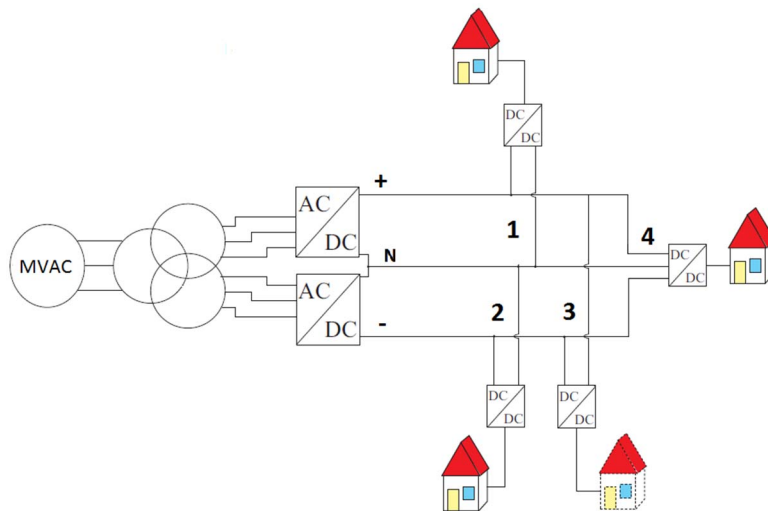

Figure 3: Bipolar DC grid

In the unipolar topology, all consumers are connected to one voltage level. The system has a plus and a minus conductor, which is also called the return conductor.

The bipolar topology has the disadvantage that different loads on the poles can cause asymmetrical voltages on the supply from the converters [5]. Therefore a voltage balancing method is needed. This makes the design of a bipolar application more complex [6]. The unipolar system does not have this problem. For this reason, a unipolar topology is chosen for the design of the DC grid.

The DC substation will be supplied from the MV AC grid. Because of the boundary condition that as much as possible standard available components should be used, the secondary voltage of the MV transformer has been chosen 400 VAC. The transformer is a regular distribution transformer and also a regular LV AC distribution panel can be used. In this way, the AC part of the DC substation is much alike a standard AC distribution station. See figure 4.



Figure 4: 1 MW DC distribution station

A common voltage level for traction supply applications is 750 VDC and DC components are available for this. Therefore 750 VDC has been chosen as the LV DC voltage level.

Active Front-Ends (AFE's) are used to convert the 400 VAC voltage into 750 VDC. An AFE ensures the possibility of a bidirectional power flow. In order to ensure reliability and availability of the DC grid, the number of AFE's is chosen $n-1$, i.e. if one converter fails, the remaining converters are still capable to supply the required 1 MW. For reduction of the number of AFE's and to avoid asymmetry problems, a unipolar DC distribution grid has been chosen.

At the customer side, the 750 VDC will be converted into a voltage type and level that is convenient for the customer. This might be e.g. 230 or 325 VDC by means of an installed DC/DC converter at the customer. But also a regular 3-phase 400 VAC could be created with a frequency converter at a fixed 50 Hz frequency and additional filtering.

Protection Concept

It is important that the system is protected against short circuit currents. As availability of the DC supply is very important, faults in the installation should be switched off without influencing the rest of the installation. Complicating factor is that all converters have large filter capacitors, which generate a large peak current at the instant of the short circuit (figure 5) [7].

For optimal protection, fuses have been chosen instead of circuit breakers.

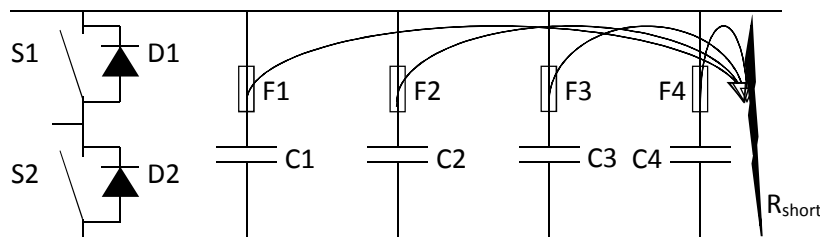

Figure 5: Short circuit on the DC rail

Theoretically, the short circuit current can become very large. In case the short circuit resistance is only $1\text{ m}\Omega$, the initial short circuit current will be 750 kA !, see figure 6. This will result in unacceptable short circuit forces. Therefore measures to reduce the short circuit forces and the short circuit currents are necessary.

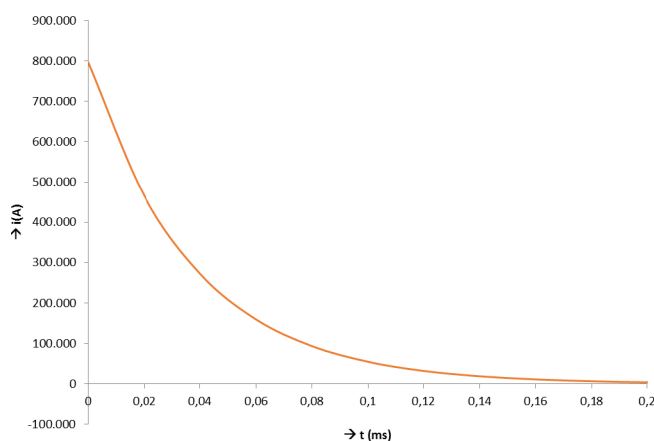

Figure 6: Short circuit current as function of time assuming low circuit inductance

Addition of an additional inductor in the circuit (figure 7) can reduce the peak value of the current to approximately 40 kA .

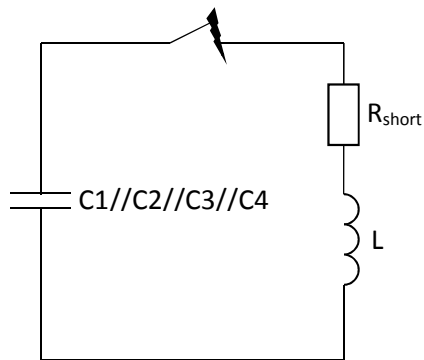

Figure 7: Short circuit impedances

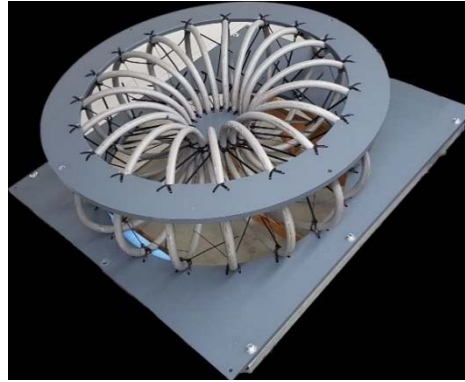

Figure 8: dI/dt limiting inductor

Every customer has its own cable connection to the DC substation. In case of a short circuit in the cable or at the customer, this might result in blowing several fuses in the total installation and not only in the connection to the fault location. In order to prevent the AFE's fuses from blowing before the fuse of the customer, additional dI/dt limiting inductors are added. Simulations have been set up to investigate the occurring currents under various fault conditions. The different components of the DC grid, like AFE's, capacitors, cables, current limiting coils and fuses, and the whole DC grid in various configurations have been put into a Matlab Simulink simulation model. Then calculations were done to determine the prospective DC short circuit current, without fuses and with fuses until the pre-arcing times of the fuses in the circuit have been reached, and the current cut-off (figure 9).

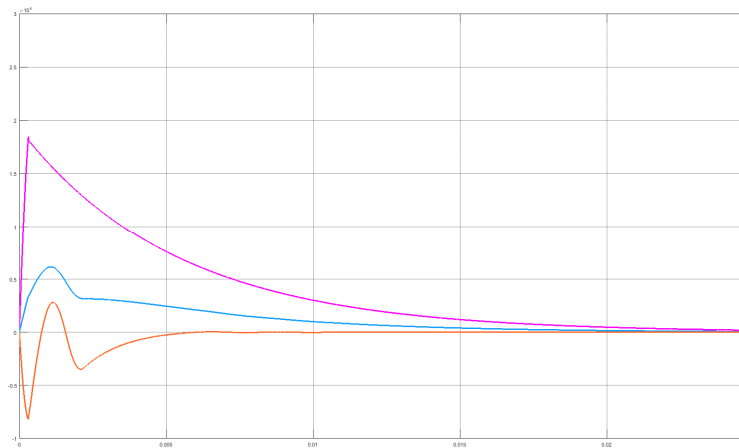

Figure 9: Short circuit fault currents

Pink: Cut-off short circuit current, Blue: AC/DC converter current, Orange: DC/DC converter current

The turn-off timing of the contributing short circuit currents have been investigated for mutual selectivity. This analysis has shown that selectivity will always be reached in bottom-up direction and most often in between client connections. There may not be discrimination under certain circumstances of load size and cable length.

Earthing Concept

A very important boundary condition is safety for humans, animals and the environment. In order to fix the voltage level to earth potential, the minus of the connection is connected to earth in the DC distribution system. As a consequence, the star connection shall not be connected to earth to prevent a short circuit situation. This is an important difference with a conventional AC distribution station.

Figure 10 shows the short circuit loop during the negative period of the phase voltage U_c over the freewheel diodes. The same happens during the negative periods of U_a and U_b . If the earthing system is of the IT-type, the short circuit will not occur. This will then only happen in case of an earth fault.

To prevent this short circuit situation, the star connection on the secondary side of the transformer should be IT-type [8][9], so no connection to earth.

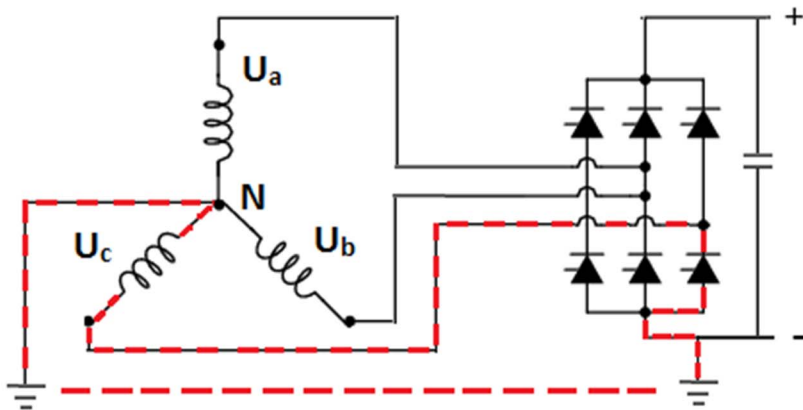

Figure 10: Short circuit loop with earthed star connection

Also the shield is connected to earth. This double connection ensures a safe earth connection (figure 11). In order to prevent stray currents, at the client side, the minus may not be connected to earth. Surge arresters will be installed at the customer side to prevent high voltages due to faults or switching activities for the protection of the customer's installation.

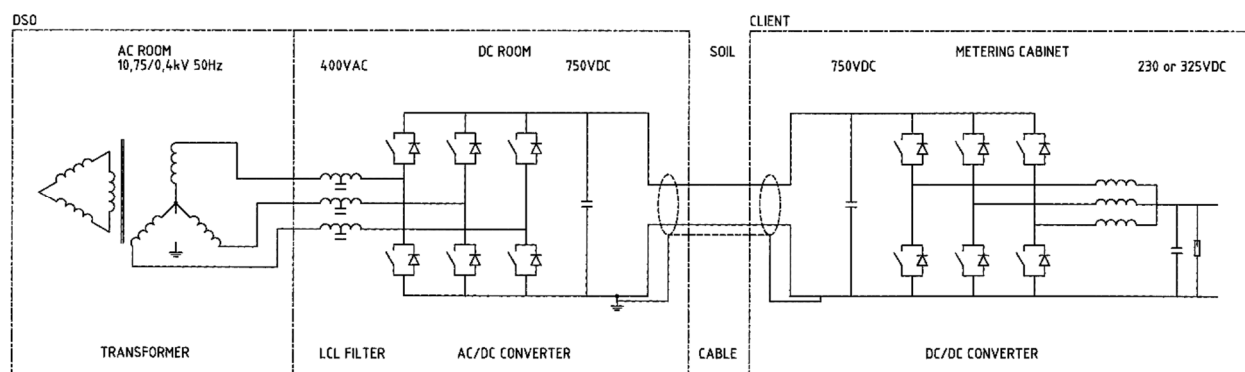

Figure 11: Earthing concept DC grid

The plus and minus conductive conductors will be isolated and non-touchable (compare: phase and neutral of a home installation).

The negative conductor will have low potential to earth because it is grounded in the DC station, conducts current and is of such a diameter that there is a maximum ($5/2 \Rightarrow$) 2.5% voltage drop, that is ($0.025 \cdot 750 \Rightarrow$) 18.75 V. This is significant lower than the max. 120 V requirement according to EN 50122.

In case of a short circuit, the touch voltage may be greater than 120 V; this is acceptable for a short period, see figure 12.

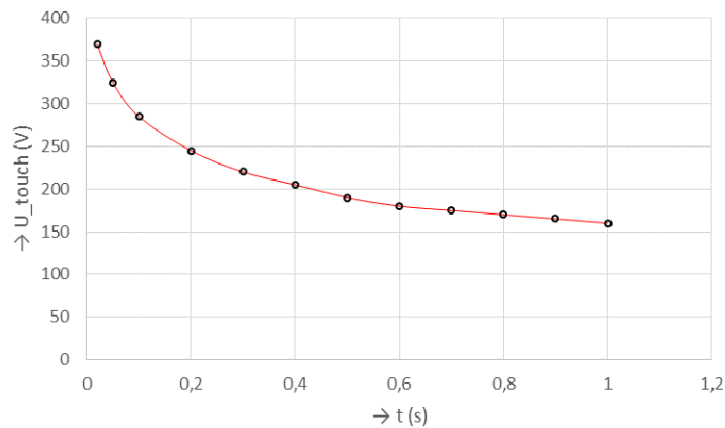

Figure 12: Touch voltage as a function of time (EN 50122)

Active Front-End

The Active Front-End is built up of four 350 kW 2-level power converters (figure 13). Therefore, one converter may be in failure or switched off, while the substation can still supply the full power of 1 MW. When the distribution station is under full load, under normal operating conditions, the AFE's are loaded only 75% of their nominal value. Stable parallel operation is realized with droop control of 4%. Special attention should be paid to precharging the DC-capacitor of the AFE in order to prevent large inrush currents. As the distribution station is unmanned, precharging should not only be done during commissioning, but should also be performed automatically after a dip in the medium voltage supply.



Figure 13: AFE converter panel

Next steps

At the time of writing the compact station and panels are all under construction. A Factory Acceptance Test of the assembled electrical installation is in preparation. Soon after that the whole building will be transported to site in Lelystad, where the 10 kV cabling will be connected. Then a Site Acceptance Test and Commissioning will be done.

It is foreseen that mid-2017 the substation will be operational, and ready to receive the DC customers.

Conclusion

This paper describes the design of a LV DC distribution system for a business park. The European Union directive 2006/95/EC enables DC voltage to be used in electricity distribution systems up to 1,500 VDC [3].

For a LV DC distribution system, many topologies are possible. In this paper, the design of a unipolar 750 VDC distribution system is described. The minus conductor of the 750 VDC distribution system is grounded in the distribution station. Also the shield of the cable is connected to ground at the distribution station, thus creating a double earth connection to the customer.

For improved reliability, every customer has its own cable, directly to the distribution station.

Reliability is further improved by redundancy of the AC/DC converters.

The LV DC distribution system is more complex than a traditional LV AC distribution system. The use of power converters introduces new fault situations and complicate protection systems. Therefore, special attention should be paid to system protection and operation.

References

- [1] M.A.V. Evans, "Why Low Voltage Direct Current Grids?", TU Delft, Delft, 2013.
- [2] P. Savage et al., "Analyses written at the request of REIL", Yale school of forestry and environmental studies, 2010.
- [3] European Commission, Low Voltage Directive, LVD 2006/95/EC. European Union Directive, Brussels, 2006.
- [4] P. Salonen, T. Kaipia, P. Nuutinen, P. Peltoniemi, J. Partanen, "An LVDC Distribution System Concept", IEEE, Birmingham, 2015.
- [5] J. Karpanen, T. Kaipia, P. Nuutinen, A. Lana, P. Peltoniemi, "Effect of Voltage Level Selection on Earthing and Protection of LVDC Distribution Systems", IEEE, Birmingham, 2015.
- [6] Ki-Woong Shin, Hee-Jun Lee, Seok-Jin Hong, Seung-Wook Hyun, Young-Real Kim, Chung-Yuen Won, "The Voltage-doubler Rectifier type Full-bridge Converter built in Voltage-balancing circuit for Bipolar LVDC Distribution System", IEEE, Korea, 2015.
- [7] G.M.B. Abdullah, S. Emhemed, "Protecting the last mile and enabling an LVDC distribution network", University of Strathclyde, 2013.
- [8] P. Salonen, "A Study of LVDC Distribution System Grounding", IEEE, Lappeenranta, 2016.
- [9] Lulu Li, Jing Yong, Liqiang Zeng, and Xiaoyu Wang, "Investigation on the System Grounding Types for Low Voltage Direct Current Systems", Electrical Power & Energy Conference (EPEC), IEEE, 2013.